

56 LENS & LENS GASKETS

17-106

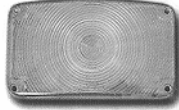

17-107



- 17-106 PARK LIGHT LENS, Clear, 'Guide', ea. 5.75 R
- 17-107 PARK LIGHT LENS, Amber, 'Guide', ea. 5.75 C
- 17-123 GASKET, park lens, cork, ea. 1.25 R



17-186



17-192

- 17-136 TAIL LIGHT LENS, w/ blue dot installed, ea. 8.75 C
- 17-186 TAIL LIGHT LENS, 'Guide', ea. 5.75 R
- 17-124 GASKET, tail lens, cork, ea. 1.25 R

17-192

CUSTOM TAIL LENS, 56 Covers entire tail light housing area within bezel. Smooth dark exterior reflectorized inside surface. Note: gas filler must be relocated, Pr. 54.75 C

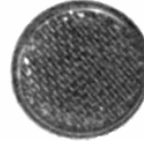

17-133

17-112



- 17-112 BACK-UP LENS, Clear, 'Guide', ea. 5.75 R
- 17-113 BACK-UP LENS, Amber, 'Guide', ea. 5.75 C
- 17-115 LICENSE LIGHT LENS, clear, 55-6 pr. 6.50 R
- 17-125 GASKET, back-up lens, cork, ea. 1.25 R
- 17-126 GASKET, license light lens, rubber, pr. 4.00 R
- 17-133 Tail Light REFLECTOR, Ea. (Trim Parts) 17.00 R
- 17-133A Tail Light REFLECTORS, Pr. foreign made 9.50 RF

57 LENS & LENS GASKETS

17-108

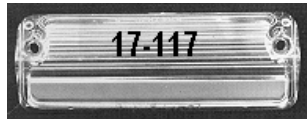

17-117

- 17-108 PARK LIGHT LENS, Clear, 'Guide', ea. 5.25 R
- 17-109 PARK LIGHT LENS, Amber, 'Guide', ea. 5.25 C
- 17-127 GASKET, park light lens, cork, ea. 1.25 R
- 17-117 LICENSE LIGHT LENS, all except wagons w/gasket 12.90 R
- 17-117TP LICENSE LIGHT LENS, exc. wgn w/silver highlights 14.75 R

17-193

TAIL LIGHT LENS, w/blue dot installed, ea. 9.50 C

17-114

BACK-UP LENS, clear Glass, ea. 9.90 R

17-128

GASKET, tail lens, cork, ea. 1.25 R

17-129

GASKET, back-up lens, cork, ea. 1.25 R



12-141A

21-201

- 12-141A 57 BACK UP LAMP ASSEMBLIES, Complete housings, retainers, lens, gaskets, includes harness, has non-original boots, Pr. (Danchuk) 137.00 R
- 12-201 BACK UP LAMP HOLE COVER, 57 for bumper end, Ea. 22.90 R
- 20-257 Back Up Lamp HOLE COVER RETAINING BRACKETS, 57 Pr. 6.00 R

17-132



17-193



17-114



- 17-132 TAIL LIGHT LENS, 'Guide', ea. 4.95 R

LICENSE LIGHT ASSEMBLY

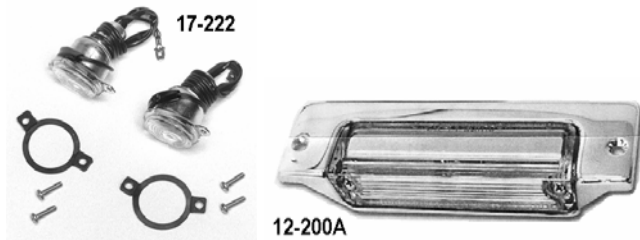

17-222

12-200A

57 License Light Assembly

- 12-200 57All except wagons 24.00 RF
- 12-200A 57All except wagons best quality [Danchuk] 46.90 R

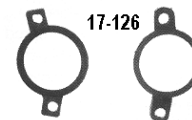

17-126

- 12-142 WAGON LICENSE LIGHT BEZELS, chrome, pr. see Grp 12
- 17-115 LICENSE LIGHT LENS, clear, wagons pr. 6.50 R
- 17-224B License LIGHT ASSEMBLY REBUILD Kit pr includes screws. Lens bulb, socket, wire & gaskets 18.00 R
- 17-126 GASKET, wagons, license light lens, rubber, Pr. 4.00 R

- Includes: lens, gaskets, bulbs, sockets, wire, housing Pr.
- 17-222 55 all, 56 & 57 Wagons 32.00 R
  - 17-223 56 except wagon pr. (wagons use 17-222) 32.00 R

Blue Dots

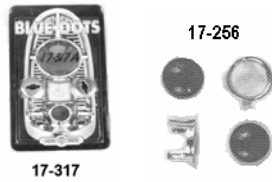

**17-256** BLUE DOTS, w/chrome bezels, glass dots, Pr. **5.00 C**

**BOWTIE BLUEDOTS**, pr. **22.00 C**

**17-317B** BLUE **17-317R** RED **17-317A** AMBER

BOWTIE LENSES

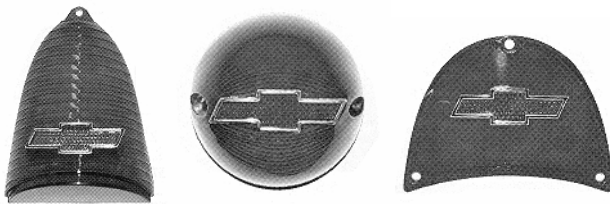

BLUE BOWTIE TAIL LENSES

Tail lens with Blue Bowtie with chrome border

**17-A1020B** 55 **33.75/Pr.** **17-A1380B** 56 **33.75/Pr.**  
**17-A1480B** 57 **36.50 /Pr.**

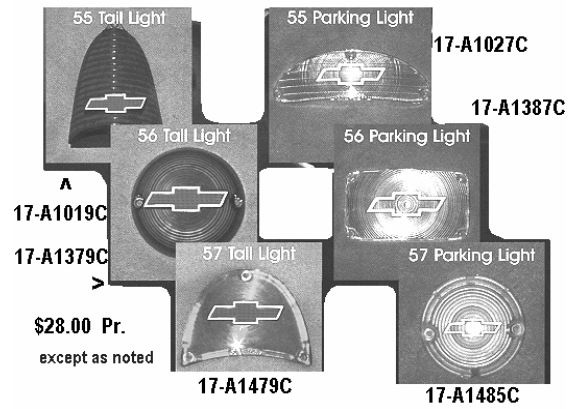

**17-A1026** 55 Park Lens Amber, Pr  
**17-A1026C** 55 Park Lens Amber, chrome 'Bowtie' Pr  
**17-A1027** 55 Park Lens Clear, Pr  
**17-A1027C** 55 Park Lens Clear, chrome 'Bowtie' Pr  
**17-A1019** 55 Tail Lens, Pr **\$29.00**  
**17-A1019C** 55 Tail Lens, chrome 'Bowtie' Pr **\$29.00**  
**17-A1386** 56 Park Lens Amber, Pr  
**17-A1386C** 56 Park Lens Amber, chrome 'Bowtie' Pr  
**17-A1387** 56 Park Lens Clear, Pr  
**17-A1387C** 56 Park Lens Clear, chrome 'Bowtie' Pr  
**17-A1379** 56 Tail Lens, Pr  
**17-A1379C** 56 Tail Lens, chrome 'Bowtie' Pr  
**17-A1484** 57 Park Lens Amber, Pr  
**17-A1484C** 57 Park Lens Amber, chrome 'Bowtie' Pr  
**17-A1485** 57 Park Lens Clear, Pr  
**17-A1485C** 57 Park Lens Clear, chrome 'Bowtie' Pr  
**17-A1479** 57 Tail Lens, Pr  
**17-A1479C** 57 Tail Lens, chrome 'Bowtie' Pr

L.E.D. LENSES

**21-437A** L.E.D. FLASHER, Necessary if more than 2 LED lenses used **9.90 C**

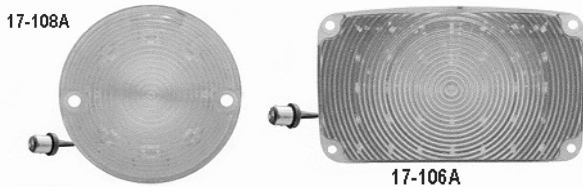

L.E.D. PARK LENS by United Pacific

**17-104A** 55 Pr, Clear lens, amber lite **63.90 C**  
**17-106A** 56 Pr, Clear, amber lite 35LED **64.00 C**  
**17-108A** 57 Pr, Clear lens, amber lite [9] **29.90 C**



L.E.D. TAIL LENS by United Pacific

**17-189B** 55 RED [60] Plug-in socket type. Pr. **62.00 CF**  
**17-189C** 55 CLEAR [60] Plug-in socket type. Pr. **62.00 CF**  
**17-110C** LED CLEAR BACK-UP LENS [26] 55 Clear Plug-in Pr. **99.00 CF**  
**17-186A** 56 RED [40] No Plug, Splice in. Pr. **49.90 CF**  
**17-186B** 56 CLEAR [40] No Plug, Splice in. Pr. **49.50 CF**  
**17-112A** LED CLEAR BACK-UP LENS [26] 56 Clear Plug-in Pr. **99.00 CF**



**17-132A** 57 RED [39] Plug-in socket type. Pr. **55.00 CF**  
**17-132B** 57 CLEAR [39] Plug-in socket type. Pr. **55.00 CF**

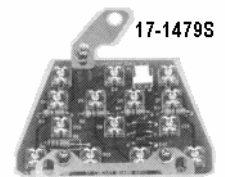
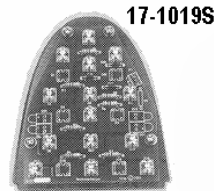

L.E.D. Kits Made in USA by TRIMPARTS w/wiring kit & instructions

**17-1019S** 55 Tail pr **126.00**  
**17-1379S** 56 Tail pr **128.00**  
**17-1479S** 57 Tail pr **127.00**

**17-132DAK** Dakota Digital 57 LED Tail Light Kit, Pr., lens not included, requires removal of light socket from housing, made in USA **129.95**  
**17-186DAK** Dakota Digital 56 LED Tail Light Kit, Pr., lens not included, requires removal of light socket from housing, made in USA **129.95**  
**17-189DAK** Dakota Digital 55 LED Tail Light Kit, Pr., lens not included, requires removal of light socket from housing, made in USA **139.95**

Small Bulbs

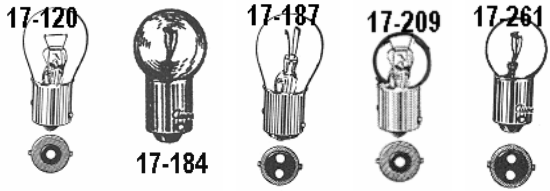

- 17-184A** DASH BULB SET, 55-6; cluster, clock, radio, heater **15.00 R**
- 17-184B** DASH BULB SET, 57; cluster, clock, radio, heater **15.00 R**

- 17-120** BULB, single contact for back-up sockets, Ea. **1.00 R**
- 17-184** BULB, dash light (53), Ea. (dash warning lights) **.95 R**
- 17-262** BULB, dash light (57), Ea. (brighter than 17-184) **.85 R**
- 17-261** BULB, double contact Large dome light, Ea. **.95 R**
- 17-261A** BULB, double contact Small dome housing, all with 2 dome lamps 55 2 dr Ht and some nomads. Ea. **.95 R**
- 17-187** BULB, park or taillight, Ea. **1.00 R**
- 17-209** BULB, license light sockets, & 55-6 clock **1.00 R**
- 17-257** 'BRIGHT' BULB, park or tail, much brighter than standard bulb, Ea. **6.50**
- 17-225A** LED License Plate Fastener, Pr **19.90 C**

Headlight Bulbs, Rings, Holders & Buckets

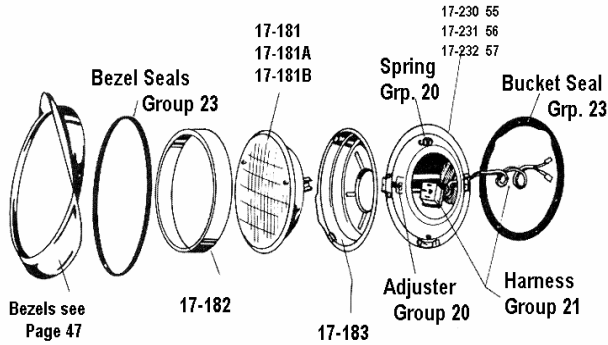

- 17-182F** Headlight BULB RETAINING RING 3 screw type, now made in USA, Ea. **11.00 R**
- 17-182S** Headlight BULB RETAINING RING type with slot for tab on bulb holder, Ea **11.00 RF**
- 17-183F** Headlight BULB HOLDER orig. style, bulb sits in this part, use with 17-182 or 17-182F Ea. **26.00 RF**



- HEADLIGHT BUCKETS**
- includes bezel clips & bulb adjusters installed
- 17-230** 55 Ea. **45.00 R**
  - 17-231** 56 Ea. **45.00 R**
  - 17-232** 57 Ea. **45.00 R**

- HEADLIGHT BULBS**
- 17-181** REPLACEMENT Sealed Beam, Ea. **7.75 RP**
  - 17-181A** 'T-3', Repro of original 56-7 Sealed Beam, Pr. **99.50 R**
  - 17-181B** HALOGEN Sealed Beam, Ea. **19.50 C**
  - 17-255** Headlight Bulb, HALF-MOON COVERS, pr. **9.00 C**

Interior Courtesy Light Lens & Bezels

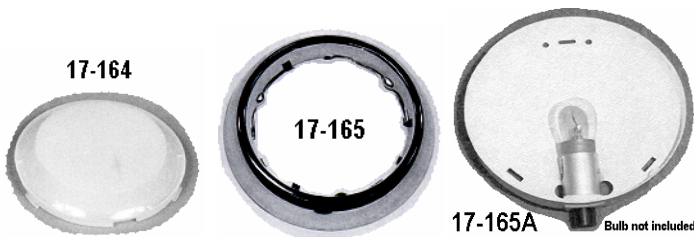

- 17-164**
- 17-165**
- 17-165A** Bulb not included
- DOME LIGHT LENS**
- (Interior Courtesy Light) Large type, All models w/single light
- 17-130** Replacement circle pattern, **5.50 RP**
  - 17-164** Original smooth cream colored lens, **6.75 R**
  - 17-164W** Original smooth lens, in white **6.75 RP**
  - 17-165** Dome Lens BEZEL, chrome, for large single light **10.75 R**
  - 17-165A** Dome LIGHT HOUSING, 55-60 all with large single type in middle of headliner **25.00 R**
  - 17-165F** DOME LIGHT HOUSING Danchuk version of 17-165A **19.95 R**

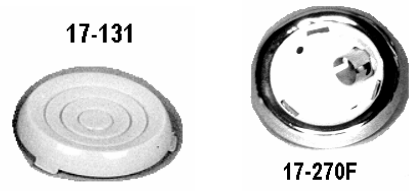

- 17-131** DOME LENS, SMALL, for 2 light roofs, 55 HT, 55 & 57 Nomad, Ea. **4.50 R**
- 17-270F** DOME LIGHT HOUSING ASSEMBLY, 53-55 HT/all Nomads, complete w/lens, no bulb, 2 required Ea. **28.75 R**
- 17-270A** Dome Light WIRE CONNECTOR to dome lite housings sedan or HT, snaps into original housing. Crimp style. Ea. **.85 RP**
- 17-131A** Small Dome Lens, SMOOTH, 55 HT, 55 & 57 Nomad Ea **3.85 RP**

**GROUP 17B**

**RADIATOR**



- Vintage Air 'Slyder' Hose Clamps Polished Aluminum
- V-31102** 5/8 Heater Hose Ea. **13.00 C**
  - V-31103** 3/4 Heater Hose Ea. **14.00 C**
  - V-31104** 1 1/2 Rad Hose Ea. **17.50 C**
  - V-31105** 1 9/16 Rad Hose Ea. **17.50 C**
  - V-31106** 1 3/4 Rad Hose Ea. **18.00 C**



**HOSE CLAMPS Original Spring Clamps**

- 17-141** Radiator & Heater Set of 8 55-6 all, 57 Standard Heater **5.50 R**
- 17-142** Radiator only, Set of 4, all **3.30 R**
- 17-143** Radiator & Heater, Set of 10, 57 Deluxe Heater **6.25 R**
- 17-144** 5/8" heater hose spring clamp, ea. **.75 R**
- 17-145** 3/4" heater hose spring clamp, ea. **.75 R**



**THERMOSTAT COVERS custom**

- 30-068A** Early Straight type, chrome ea. **11.00 C**
- 30-068B** Early Straight type O-ring gasket, chrome ea. **9.00 C**
- 30-068C** Straight Up type O-ring gasket, chrome ea. **9.00 C**
- 30-068C1** STRAIT UP Billet, polished, 'O' ring style, Each **15.00 C**



**UPPER Radiator Hose, Molded**

- 17-137** 6 cyl, Upper w/GM #, 55-56 **16.75 R**
- 17-280** 6 cyl, Upper w/GM #, 57 **30.00 R**
- 17-139** V8, Upper w/GM #, all exc. 2-4's and FI **21.00 R**
- 17-139A** V8, Upper 2-4's & Fuel Injection w/GM # **45.00 R**
- 17-139B** V8, Upper, custom for cars w/rad. mounted in front of support, can be trimmed to fit most applications **19.75 C**



- 30-068D** 90° Swivel O-ring, polished aluminum ea. **17.00 C**
- 30-068E** 40° Swivel O-ring, polished aluminum ea. **16.50 C**
- 30-068F** 15° SWIVEL Billet, polished, 'O' ring style, Each **17.00 C**



- 30-068G** HARD LEFT ANGLED Chrome, 'O' ring style, Each **13.50 C**
- 30-068H** SOFT LEFT ANGLED Chrome, 'O' ring style, Each **12.00 C**
- 30-068J** LEFT ANGLED w/pipe thread boss on top, Chrome, 'O' ring style, Each **12.00 C**

- LOWER Radiator Hose, Molded**
- 17-138** 6 cyl, Lower w/GM # 55-57 **27.90 R**
  - 17-140** V8, Lower w/GM # **21.00 R**
  - 17-140B** V8, Lower, custom for cars w/rad. mounted in front of support, can be trimmed to fit most applications **17.50 C**
  - 17-140B1** V8, Big Block, Lower, all **29.90 C**
  - 17-140D** 'LS' motors to 17-GRIF19 Radiator **18.90 C**
  - 17-140B2** V8 motors w/1.5" outlet to 6 cyl position radiator, usually serpentine reverse rotation **18.90 C**
  - 17-140D** Lower RAD. HOSE LS motors to 17-GRIF19 Radiator **18.90 C**
  - 17-140B2** Lower RAD. HOSE V8 motors w/1.5" outlet to 6 cyl position radiator, usually serpentine reverse rotation **18.90 C**



**RADIATOR CAPS**

- 17-146** 7 lb. Stock **9.95 RP**
- 17-300** EXACT ORIGINAL with original markings **29.95 R**
- 17-146A** 13 lb. use with US Radiator repro radiator **10.25 C**
- 17-146D** 13 lb. use with US Radiator & Overflow tank **9.50 C**
- 17-146E** 16 lb. use with Griffin Rad & Overflow tank. **9.50 C**
- 17-GRIF20D** 16 LB Griffin Radiator Cap Steel **24.00 R**
- 17-147A** BILLET RADIATOR CAP, polished 14 lb **19.90 C**
- 17-171A** FILLER PANEL, V8 Radiator Support lower **19.90 R**



- 17-194** THERMOSTAT COVER, iron, all V8 exc 2 4's & FI **17.50 R**
- 17-195** GASKET, thermostat cover, all **1.65 R**
- 17-196** THERMOSTAT, 160 degree (AC) **9.95 R**
- 17-197** THERMOSTAT, 180 degree, (AC) **10.90 R**
- 17-197A** THERMOSTAT, 195 degree, (AC) **9.75 R**

- 
- 17-148** PETCOCK, for radiator drain as original **3.95 R**
  - 17-148A** DRAIN HOSE, for Radiator Petcock **1.50 R**
  - 17-148RP** PETCOCK Replacement has no tube for hose **3.50 RP**
  - 17-149** DRAIN PLUG, Engine block, 2 required, Ea. **.50 R**

17-277

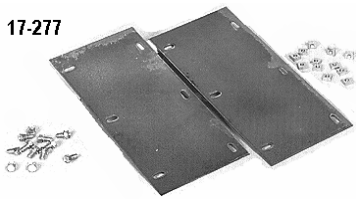

17-005

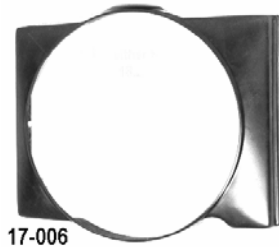

17-006

**17-277** Radiator RELOCATION PLATES, kit allows moving V8 mount radiator to front of V8 support for custom applications where more room is needed **48.50 C**

**17-277SS** Radiator RELOCATION PLATES, Stainless not polished, use to move V8 rad to front of V8 support, round corners, stainless button head hardware supplied [stainless version of 17-277] **59.50 C**

**17-005** INSECT SCREEN, 56-7 *original Accessory for front of Radiator* **25.00 R**

**17-005A** INSECT SCREEN, all Black Replacement Discontinued

**FAN SHROUDS, ABS PLASTIC**

Important Notes: Fan opening in either is 18.25". With V8 shroud & Power Steering use Fan #28-127C or #27-127E2

**17-006** Stock V8 position, Rad behind support, **89.00 C**

**17-006-1** Stock V8 position, Rad behind support, Danchuk **99.75 C**

**17-006A** Stock '6' position, Rad in front of support, **89.00 C**

**17-006A-1** Stock '6' position, Rad in front of support, Danchuk **99.75 C**

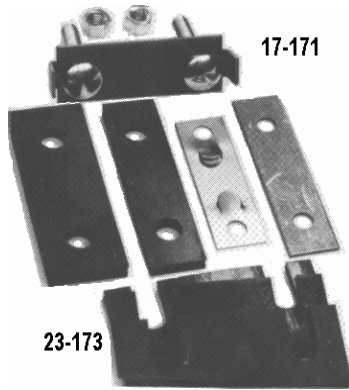

17-171



17-172

23-173

**RADIATOR SUPPORT TO FRAME**

**17-171** CENTER MOUNT KIT, bolts, metal plates & brackets **8.75 R**

**23-173** SHIM KIT, at CENTER all, fiber & rubber shims **8.80 R**

**17-172** SHIM KIT, at SIDES, metal, to fenders 55-56 **6.95 R**

**17-173** SHIM KIT, at SIDES, & grill tie bar to fender, metal, 57 **8.35 R**

**17-171-S** Rad Support Bottom Mounting Kit with 17-171 and 23-173 shims **15.00 R**



17-007B

**FAN SHROUDS, ALUMINUM (GRIFFIN)**

Important Notes on Universal Aluminum Fan Shrouds below:

1. Fan Hole is Not Cutout. 2. Shroud is not polished or finished.

3. Other alterations may be necessary due to your car and/or options.

**17-007B** Stock V8 position, Radiator behind support **299.95 C**

**17-007C** Stock '6' position, Radiator in front of support **299.95 C**

**Stock Replacement RADIATORS**

Please READ the following Notes !

**NOTES:** Original V8's all mounted radiator on engine side of radiator support, original 6 cyl. cars mounted radiator on grill side of support. If your car is not stock, please check your mounting before ordering. Aside from the way they are mounted the cooling capacity is the same from 6 mount to V8 mount in each model.

All radiators are coded 'RP' because tanks have no numbers on them. Note; V8 position radiators #'s 17-243, -244, -274, -275 have a 3" wide bottom tank 3/4" wider than stock this requires alteration to filler panel in bottom of support, bending or moving it forward or its removal. \*Oversize shipping. Part #'s 17-278, 278A, 279, 279A recommended for big block installations. For modified cars it is better to mount radiator in the 6 cyl position, this allows more room for different fans & multiple pulley applications.

For answers to questions on engine temp. & overheating see Radiator tech notes in back of catalog.



17-244

Original Type RADIATORS Copper/Brass (No Numbers on Tank) **made in USA by US Radiator**

**'DESERT COOLER'** 4 row core **\$375.00\*** RP

**17-243** V8 stick **17-244** V8 auto  
**17-278A** 6 cyl. Mnt. auto, 57 **17-279** 6 cyl. Mnt. stick, 55-6

**17-278** 6 cyl. Mnt. auto, 55-6  
**17-279A** 6 cyl. Mnt. stick, 57

**Normal Duty** 3 row core **\$320.00\*** RP

**17-275** V8 stick **17-274** V8 auto,  
**17-271A** 6 cyl. auto, 57 **17-272** 6 cyl. stick, 55-6

**17-271** 6 cyl. auto, 55-6  
**17-272A** 6 cyl. stick, 57

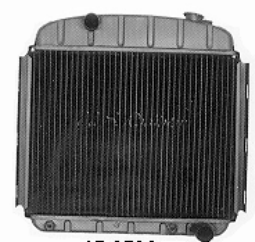

17-278A

**Tech Note** You can use 13# cap on Replacement Radiators

Aluminum Radiators from US Radiator

<b>17-AL10040</b>	V8 mount stick or automatic	<b>380.00</b>
<b>17-AL10040P</b>	#17-AL10040 above polished	<b>480.00</b>
<b>17-AL100408</b>	6-cyl-mount stick or automatic <u>has center upper hose nipple</u>	
	requires mods to 57 hood brace to clear hose	<b>380.00</b>
<b>17-AL100408P</b>	#17-AL100408 above polished	<b>480.00</b>
<b>17-AL10057</b>	6 Cyl mount stick or auto in front of rad support 57 curved left nipple	<b>380.00</b>
<b>17-AL10057P</b>	#17-AL10057P above polished	<b>480.00</b>
<b>17-AL10056</b>	Crossflow stick or automatic	<b>380.00</b>
<b>17-AL10056P</b>	#17-AL10040 above polished	<b>480.00</b>
<b>17-AL100561</b>	Crossflow stick or automatic w/1620 cfm dual Spal fans & shroud	<b>679.50</b>
<b>17-AL100561P</b>	#17-AL100561 Crossflow kit above polished	<b>779.50</b>



17-AL100408

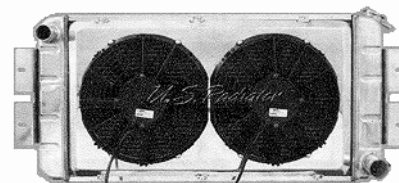

17-AL100561

2 row 1" tubes Polishing available

'Griffin'®Aluminum Radiators

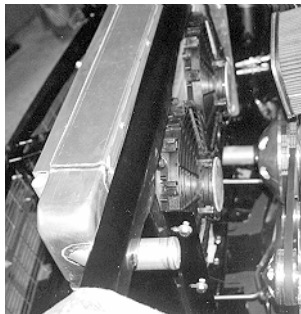
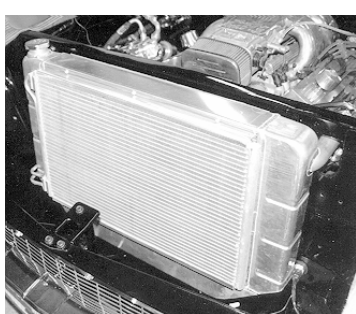

17-GRIF15KIT-POL



**17-GRIF19** Griffin CROSS FLOW ALUMINUM RADIATOR KIT  
Mounts in front of rad support. Comes with dual fans, AC Condenser & Griffin rad cap. Assembly mounts directly to V8 rad support and uses stock V8 lower rad hose as rad has lower extended tube from unique 3<sup>rd</sup> tank on bottom. Auto trans lines go in bottom of tank like stock. Upper hose goes thru left side filler panel. AC hoses go thru right side Also available; for LS motors & other applications. Call [Polishing also available at additional cost, also available without condenser or fans,

**17-GRIF19A** V8 Mount CROSS FLOW Radiator ONLY **1350.00\***  
**650.00\***

**17-GRIF15KIT** Griffin Crossflow Radiator SET 'L' bracket style mount includes AC Condenser, Shroud w/Dual Fans and Radiator Cap, 2-1-1/4" tubes 2780 cfm fans. Polishing available for extra charge **1350.00\***

**17-GRIF15KIT-POL** Griffin Crossflow Set POLISHED **1625.00\***

**17-GRIF15** Griffin CROSS FLOW Aluminum Radiator mounts in front of rad. support. Has 'L' brackets on each side, mount to rad side filler panels. [if you have 6 cyl support you will need to remove rad. mounting tabs] **650.00\***

**V-03455-VCC** A/C CONDENSER for 17-GRIF15 above. with mounting brackets, Unpainted aluminum **219.00**

**V-03263-VUC** A/C CONDENSER for 17-GRIF15 above. Comes w/universal mounting brackets, BLACK PAINTED only **149.00**



**17-011** Griffin Crossflow RADIATOR TOP CORE COVER w/laser in 'Chevrolet' script, 24" long 3-3/8 wide, 3-1/4 wide inside **75.00 C**

'Griffin'®Aluminum Replacement Radiators

2 row 1-1/4 tubes, equal to 4 row copper, Made in USA. This is the largest of the 2 cores offered by Griffin. All are stick or auto trans. V8 refers to rad mounting behind support, '6' refers to rad mounting in front of support. Use 15# cap on Griffin Radiators **\$575.00** 1 1/4" tube radiator

**17-GRIF7** 1 1/4" V8 **17-GRIF9** 1 1/4" '6' 55-6 **17-GRIF11** 1 1/4" '6' 57

Call for Griffin Radiator Caps several styles available  
GRIFIN Radiators Polished Add \$200.00 17-GRIF19 Kit or GRIF15 Kit Add \$275.00

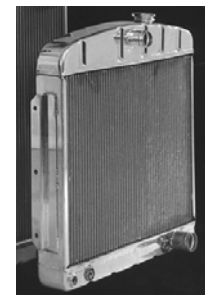

ALUMINUM Replacement RADIATOR

<b>17-KS1</b>	V8 mount, Not Polished	<b>299.00 *</b>	<b>17-KS2</b>	6 CYL mount, Not Polished	<b>299.00 *</b>
<b>17-KS1-P</b>	V8 mount, POLISHED	<b>329.00 *</b>	<b>17-KS2-P</b>	6 CYL mount, POLISHED	<b>329.00 *</b>

Soldered original style Tanks come with cap, petcock, mount bolts STICK OR AUTOMATIC, 2-1" tubes. Made in China.